

Operation Manual

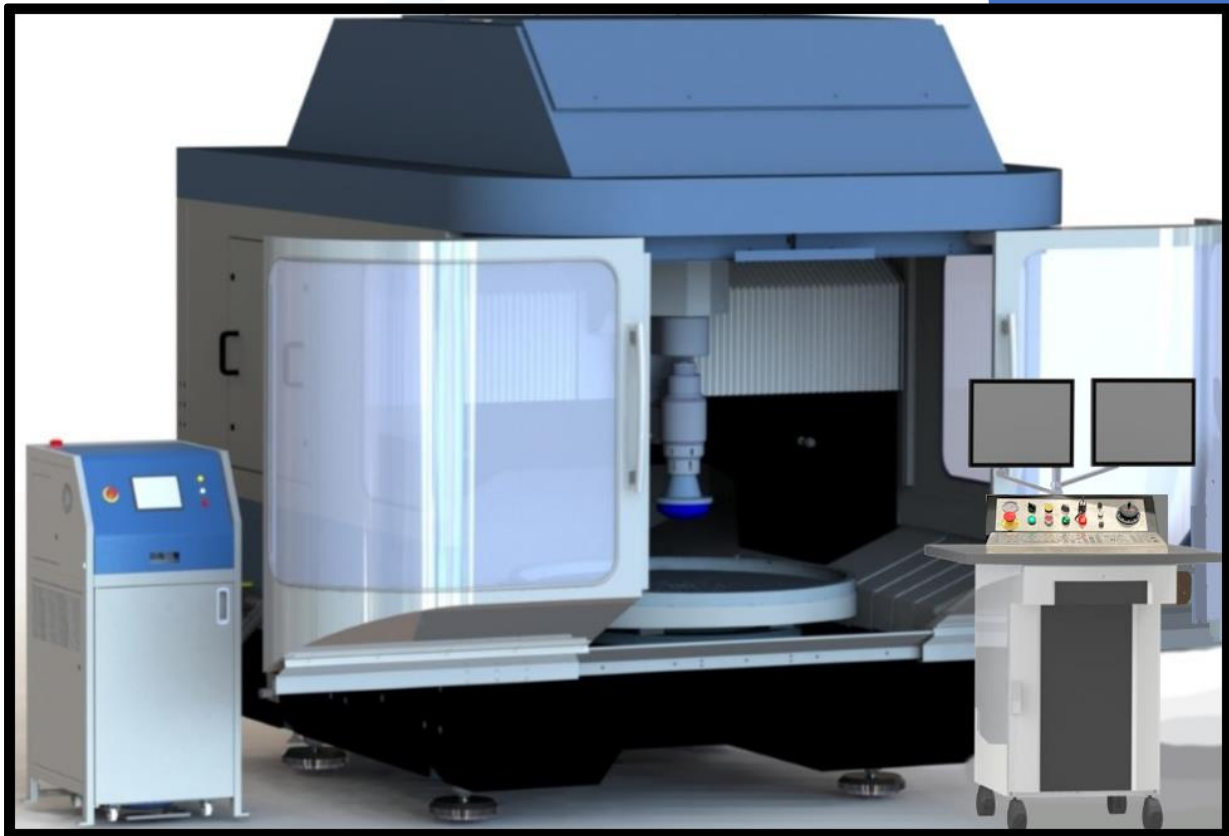

IRP1200 MK1 - Fanuc
Ballscrew

Version 2, Rev b

Sept 2024

Contents

Liability Statement.....	5
Preface.....	6
Reference manuals.....	7
Instructions for this manual	9
Safety instructions.....	10
General safety instructions.....	10
Intended use of the machine.....	10
Room temperature	11
Storage of the polishing fluid.....	11
Electromagnetic influence	11
Safety and protection devices	11
Organisational measures	12
Operator Training	13
Safety and test circuits of the control mechanism.....	14
Inspection prior to starting work.....	14
Safety instructions for working with the machine	14
Safety instructions related to programming	16
Safety instructions related to handling	17
Safety instructions for working on electrical parts.....	18
Safety instructions related to daily maintenance	19
The machine	21
Machine dimensions.....	21
Tool options	22
Continuous noise level.....	22
Power supply	23
Compressed air supply.....	23
Machine assemblies	24
Machine overview	24
Definitions of axes	24
For a “Type 1” VP machine	25
For a “Type 2” VP machine	25
Sign conventions for “Type 2” virtual pivot	26

Vertical C axis (IRP1200 Mk1)	26
X axis motions	26
Y axis motions	26
A axis motions.....	26
B axis motions	26
Z axis motions	27
C axis (Spindle and Axis modes).....	27
H axis (Spindle and Axis modes)	27
Pneumatic cabinet and switchgear cabinet	28
Pneumatics controls	28
CNC control panel	29
Operating modes	30
Manual mode.....	30
Switching ON and OFF the machine	31
Switching ON the machine	31
Referencing A&B Axes	33
Switching on the compressed air supply	35
Switching off and disconnecting the compressed air supply	37
Opening/Closing the roof	38
Switching off the machine	38
Switching off the compressed air supply.....	39
Switching off the electricity at the “MAIN SWITCH”	40
Using “Canned” programs	40
Canned programs description	40
Setting up a utilities program	41
Using the Program Transfer Tool	44
Setting up a program	44
Setting a work piece co-ordinate system (G54)	49
ZTOP.....	49
Manual offset setting.....	51
Manual control of machine axes	51
MDI mode	52
H axis in spindle configuration.....	52

IRP1200 MK1 – Fanuc Ballscrew

Operation Manual

Basic manual mode.....	53
MPG mode	53
Tool spindle and work piece spindle commands.....	54
Tool spindle (S) section	54
Work piece spindle (C) section	55
Axis over-travel.....	55

Liability Statement

Zeeko (hereinafter referred to as “the Manufacturer”) warrants that the CNC machines are free from defects in materials and workmanship for a period of one year from the date of delivery. The Manufacturer will repair or replace, at its option, any defective CNC machine or part thereof, provided that the CNC machine is returned to the manufacturer, or an authorized service engineer site visit is arranged, within the warranty period.

This warranty does not cover normal wear and tear, damage caused by improper installation, operation, maintenance, or modification, or any damage resulting from misuse, abuse, negligence, accident, or natural causes.

The Manufacturer’s liability under this warranty is limited to the repair or replacement of the defective CNC machine or part thereof, and does not include any incidental or consequential damages, such as loss of profits, loss of production, loss of data, or injury to persons or property. The Manufacturer disclaims any implied warranties of merchantability or fitness for a particular purpose, and any other warranties not expressly stated herein.

The Manufacturer is not liable for any direct, indirect, incidental, or consequential damages arising from the use or inability to use the CNC machines, whether based on contract, tort, or any other legal theory, even if the Manufacturer has been advised of the possibility of such damages. The Manufacturer’s maximum liability under any circumstances shall not exceed the purchase price of the CNC machine.

Some jurisdictions do not allow the exclusion or limitation of certain warranties or damages, so some of the above exclusions or limitations may not apply to you. This liability statement gives you specific legal rights, and you may also have other rights that vary from jurisdiction to jurisdiction.

By purchasing, installing, operating, or using the CNC machines, you agree to be bound by the terms and conditions of this liability statement. If you do not agree with this liability statement, do not purchase, install, operate, or use the CNC machines.

Preface

Dear Customer,

This Operating Manual describes all steps needed to be taken to work on the IRP1200 machine.

Please take the time to read the manual carefully. Pay attention to the instructions for this manual given on this and the next page.

This manual is structured to guide the operator in a step-by-step fashion, on how to operate the machine.

Always keep this manual in the immediate vicinity of the machine, readily available for consultation.



Wishing you a lot of success and good results with the IRP1200.

Zeeko LTD

Reference manuals

Below is a catalogue of Zeeko manuals available to you, ranging from Transport & Installation to Product Specifications. Please take the time to read through the manuals to familiarise yourself with all the workings and general maintenance of the hardware and software.

- Transport & Installation.

This Transport and Installation manual describes all steps you must take for transportation and installation of the IRP1200 machine.

- Product Specification.

This Product Specification manual describes all technical and product specifications of the IRP1200 machine.

- Operation (this manual).

This Operating Manual describes all steps needed to be taken to work on the IRP1200 machine.

- Maintenance.

This Maintenance Manual describes all maintenance jobs required for the upkeep of the IRP1200.

- Graphical User Interface (GUI).

This manual provides information relating to the Zeeko graphical user interface.

- G-Code (Fanuc).

This Operation Manual details the procedures required for operating the G-Code.

- Schunk Chucks.

This manual covers the general operation and maintenance for the hydraulic schunk chucks used on the Zeeko IRP polishing machines. The two sizes are the 25 mm and 40 mm bore chucks.

- Bonnet Dressing.

This manual outlines the steps for Bonnet Dressing. For Bonnet care please refer to the Bonnet Care manual.

- Bonnet Care.

This manual outlines the steps and precautions the operator should take to care for the Zeeko polishing bonnets. If these guidelines are followed then the bonnets will be maintained in their correct operable condition, with maximised lifetime.

- Custom Tool Paths.

This document provides guidelines to the functionality of the Custom Tool Paths module.

- Function Chart (Zeeko Polishing Machine).

This manual provides a function chart of the Zeeko polishing machine.

- ZephyrCAM Software.

This manual provides information relating to ZephyrCAM's ability to generate basic to complex tool paths for any CNC machine.

- Pneumatic Schematic.

This document displays the pneumatic schematic with the Zeeko part numbers.

These manuals are available in hard copy and in PDF format on the Pen drive provided. Please ensure you have the Operation manual close to the machine and keep all other documents and drive in a safe place.

Instructions for this manual

The following signs are used throughout the manual to depict areas of safety or general instruction. Please make yourself aware of these signs and take careful consideration when carrying out the specified maintenance tasks.



WARNING: Identifies a potentially dangerous situation which may cause loss of life, serious.



ATTENTION: Signifies a potentially dangerous situation which may cause injury or serious.



NOTE: Identifies application instructions and other useful and important information.



TIP: Specifies information that could be useful and save you unnecessary time and effort.

Safety instructions

General safety instructions

The Zeeko IRP1200 MK1 is built in accordance with the safety regulations in effect in the UK and in Europe.

Safety switches and protection devices are installed and active where necessary. This is why the machine must not be rebuilt or altered in any way.



WARNING: *Never change or deactivate safety switches or protection devices in any way.*

- Work on the machine must only be performed with the work chamber closed. The work chamber and the safeguards must not be removed or altered.
- The machine should be checked for visible damage and defects at least once during each day/shift. Any changes (including changes in the operating condition) must be reported immediately to the person or authority in charge! If necessary, the machine must be put out of service and secured, for example, locking of the main isolator switch.
- Do not perform any operations that are not described in this manual.
- The software provided by Zeeko is scanned for computer viruses prior to delivery, using the Windows Security virus scanner. Zeeko is not liable for malfunctions and damages resulting from computer viruses.

Intended use of the machine

The machine is intended to be used for:

- Light industrial purpose.
- Laboratory purpose.
- University research.
- Manufacture of optical lenses and moulds.
- Never use the machine for any purpose other than that for which it was designed for.



ATTENTION: *Safety Instruction!*

Only perform operations on work pieces made of materials recommended by Zeeko.

Do Not: *use grinding attachments.*

Do Not: *use non-recommended tooling.*

Do Not: *use unauthorised software.*

Room temperature

- The room temperature must be 20 °C +/- 1 °C.
- The change in temperature must not exceed 2 °C per day.
- The relative humidity should not exceed 80 %.
- If necessary, provide adequate air condition.

Storage of the polishing fluid

- Observe all regulations regarding the storage of polishing fluid and other chemicals associated with the machine's use, such as solvents and adhesives etc. Please observe your local COSHH and health & safety regulations before using any chemicals.

Electromagnetic influence

- Interference caused by other electrical installations (high frequency) must be avoided.

Safety and protection devices

- The "EMERGENCY STOP" button is located on the control panel and within the polishing chamber. By pressing this button all machine functions and processing cycles are immediately interrupted. It is a safety release button unlocked by turning the button clockwise.
- The work chamber is completely enclosed and interlocked. The machine can only be operated with the work chamber closed.
- This machine is fitted with a lockable Main Isolator switch.

- Individual movement of the axes is only possible in “Manual” mode. Access to “Manual” mode is key lock protected. In “Manual” mode the A-axis and Z-axis speeds are limited to 2 m/min. When in the manual mode switch position, movement of axis is restricted to an individual axis selected on the “Manual GUI” page. When in manual mode axis speeds are restricted to prevent damage to the work piece and/or machine itself, or injury to the operator.
- Program key lock prevents unintended program changes.

Organisational measures



ATTENTION: *This section covers organisational measure. Before attempting to use the machine, read the following safety measures carefully.*

- Always keep the complete documentation for the machine in the immediate vicinity of the machine and accessible to all machine operators.
- In addition to the Operation manual please observe general, legal and other binding regulations pertaining to accident prevention and environmental protection.
- The above may also apply to; for example, the handling of dangerous materials as well as making protective clothing available to the operating personnel and enforcing its wear.



ATTENTION: *In some circumstances bacterial growth can occur in the polishing fluid tank and the associated pipe work.*



ATTENTION: *Zeeko Ltd. is not aware of what type of polishing fluids, additives or agents are used and can therefore not provide any recommendations on how to prevent bacterial and viral growth.*

- All personnel authorized to operate and work with the machine must have read the Operation manual prior to working with the machine. It is too late to do so while already operating the machine. This applies particularly to personnel charged with, for example, the installation and maintenance of the machine.
- Operating personnel should at least be supervised from time to time to ensure that all operations are handled in a safety conscious manner.
- Operating personnel should not wear long/loose hair, loose clothing or jewellery including rings because of the potential danger of injury due to e.g. getting caught up or pulled into the machine. All safety instructions and warnings must be followed.
- All safety instructions and warnings on the machine must be kept in legible condition.
- The machine must be put out of service when any safety-related changes are made to the machine, or a change in the operating behaviour becomes apparent, which can influence the operating safety. Immediately report all malfunctions to the responsible party.
- Replacement parts must conform to the technical requirement of the manufacturer. These are always guaranteed for the original replacement parts.
- Do not change the programs of the programmable control systems (Canned Programs).
- Always perform the regular scheduled inspections as specified in the Maintenance manual.

Operator Training

- The machine should only be operated by personnel trained in the use of the machine and familiar with the safety instructions.
- When conducting the training, special attention should be given to the dangers and safety measures.
- This training should be repeated at regular intervals (at least once per year).
- The following table shows the skill levels required for operating and maintaining the machine: See *Table 1 - The skill levels required for operating and maintaining the machine.*

Skill Level	Operation and Function
Unskilled	Basic cleaning, supervised set-up and maintenance. Must not operate the machine.
Semi-Skilled	Basic daily inspection and cleaning of machine, machine set-up for operations, operating machine (push-button operations only).
Skilled	Machine set-up for operations, operating machine, maintenance and basic programming.
Fully Skilled	As skilled and fully trained in programming.

Table 1 - The skill levels required for operating and maintaining the machine

Safety and test circuits of the control mechanism

- All generating operations can only be performed with the work chamber doors closed.
- All data input is checked for feasibility and plausibility.
- The processing cycle is interrupted immediately when malfunctions occur.
- All malfunctions are reported in the form of on-screen messages.
- When certain faults occur, the drives are switched off automatically.

Inspection prior to starting work

- Is the work piece inserted properly?
- Is the coolant (lubricant) system working properly?
- Can other people be endangered by the running machine?

Safety instructions for working with the machine

- Read and observe all safety instructions in this manual closely. Safety Instructions are given where necessary during a processing cycle.
- Immediately interrupt the operation when you hear unusual noise or resonance in the machine. These may be due to improper clamping of the tool or work piece and could impair the operating safety. In that case, inspect the work piece and tool for damage.
- Only resume the operation when the work piece and tool are intact and undamaged.

- Never attempt to machine a work piece without first checking the operation of the machine. Before starting any machining operation or production run, ensure that the machine is operating correctly by performing a trial run using, for example, the 'FEED RATE OVERRIDE', 'SINGLE BLOCK' or by operating the machine without either a tool and/or work piece mounted. Failure to confirm the correct operation of the machine may result in the machine behaving unexpectedly, possibly causing damage to the work piece and/or machine itself, or injury to the operator.
- Before operating the machine, thoroughly check the entered data. Operating the machine with incorrectly specified data may result in the machine behaving unexpectedly, possibly causing damage to the work piece and/or machine itself, or injury to the operator.
- Ensure that the specified feedrate is appropriate for the intended operation. There is a maximum allowed feedrate specified for the IRP1200. The appropriate feedrate varies with the intended operation. If a machine is run at other than the correct speed, it may behave unexpectedly, possibly causing damage to the work piece and/or machine itself, or injury to the operator.
- When using or applying tool, work piece or axis compensation functions, thoroughly check the direction and amount of compensation. Operating the machine with incorrectly specified data may result in the machine behaving unexpectedly, possibly causing damage to the work piece and/or machine itself, or injury to the operator.
- The parameters for the CNC and PMC are factory set. Usually, there is no need to change them. Machine parameters may only be changed by Zeeko authorised trained personnel. Failure to set a parameter correctly or changing any of the factory set parameters may result in the machine behaving unexpectedly, possibly causing damage to the work piece and/or machine itself, or injury to the operator. **Zeeko will not accept any liability if CNC or PMC changes are made by unauthorised personnel.**
- Immediately after switching on the machine, do not touch any of the keys on the user interface or keyboard until the position display or alarm screen appears on the screen.



ATTENTION: *Danger of injury! The work pieces and the machining residues may be sharp and could cause skin injuries. If possible, remove the work piece and the tool from the machine before doing any work in the work chamber.*



ATTENTION: Wear protective gloves when performing any work where you can get in touch with processing residue to prevent injury. Use a brush or wooden/plastic scraper to remove processing residue.



NOTE: Programs, parameters and macro variables are stored in non-volatile memory in the CNC unit. Usually, they are retained even if the power is turned off. Such data may be deleted inadvertently, however, or it may prove necessary to delete all data from non-volatile memory as part of error recovery.

Safety instructions related to programming



ATTENTION: This section covers the major safety precautions related to programming. Before attempting to perform programming, read the following safety instructions related to programming carefully.

- Coordinate system setting - If a coordinate system is established incorrectly (G54 to G59), the machine may behave unexpectedly as a result of the program issuing an otherwise valid move command. Such an unexpected operation may damage the tool, the machine itself, the work piece, or cause injury to the operator.
- Positioning by nonlinear interpolation - When performing positioning by nonlinear interpolation, the tool path must be carefully confirmed before performing programmed movements. While positioning in rapid traverse, if the tool collides with the work piece, it may cause damage to the tool, the machine itself, the work piece, or cause injury to the operator.
- Constant surface speed control - When an axis subject to constant surface speed control approaches the origin of the work piece coordinate system, the C-axis spindle speed may become excessively high. Therefore, it is necessary to specify a maximum allowable C-axis speed. Specifying the maximum allowable speed incorrectly may damage the tool, the machine itself, the work piece, or cause injury to the operator.

- Absolute/incremental mode - If a program created with absolute values is run in incremental mode, or vice versa, the machine may behave unexpectedly.
- Plane selection - If an incorrect plane is specified for circular interpolation, helical interpolation, or any 'canned' cycle, the machine may behave unexpectedly.
- Programmable mirror image - Note that programmed operations vary considerably when a programmed mirror image is enabled.

Safety instructions related to handling



ATTENTION: *This section presents safety precautions related to the handling of the IRP1200 machine. Before attempting to perform handling, read the following safety instructions related to handling carefully.*

- Manual operation - When operating the machine manually, determine the current position of the tool and work piece, and ensure that the movement axis, direction, and feedrate have been specified correctly. Incorrect operation of the machine may cause damage to the tool, the machine itself, the work piece, or cause injury to the operator.
- Manual numeric command - When issuing a manual numeric command, determine the current position of the tool and work piece, and ensure that the movement axis, direction, direction and command have been specified correctly, and that the entered values are valid. Attempting to operate the machine with an invalid command may cause damage to the tool, the machine itself, the work piece, or cause injury to the operator.
- Manual Handle mode - In manual handle mode, rotating the handle with a large-scale factor such as x1000, causes the selected axis to move rapidly. Careless handling may cause damage to the tool, the machine itself, the work piece, or cause injury to the operator.
- Origin/preset operation - Do not attempt an origin/preset operation when the machine is operating under the control of a program. Otherwise, the machine may behave unexpectedly, possibly causing damage to the tool, the machine itself, the work piece, or cause injury to the operator.

- Work piece coordinate shift system - Manual intervention or machine lock may shift the work piece coordinate system. Before attempting to operate the machine under the control of a program, confirm the coordinate system carefully. If the machine is operated under the control of a program without making allowances for any shift in the coordinate system, the machine may behave unexpectedly, possibly causing damage to the tool, the machine itself, the work piece, or cause injury to the operator.
- Manual intervention - If manual intervention is performed during programmed operation of the machine, the tool path may vary when the machine is restarted. Before restarting the machine after manual intervention, confirm the settings of the manual absolute settings, parameters and absolute/incremental mode.
- 'FEED HOLD', 'FEEDRATE OVERRIDE' and 'SINGLE BLOCK' - The 'FEED HOLD', 'FEEDRATE OVERRIDE' and 'SINGLE BLOCK' functions can be disabled using custom macro system variable #3004. Be careful when operating the machine in this case.
- Dry run - Usually, a dry run is used to confirm the operation of the machine. During a dry run, the machine operates at dry run speed, which differs from the corresponding programmed feedrate. Note that the dry run speed may sometimes be higher than the programmed feedrate. A dry run should be implemented **without the tool or work piece** – or – with ZTOP positioned at a reasonable distance from the work piece.
- Program editing - If the machine is stopped, after which the machining program is edited (modification, insertion or deletion), the machine may behave unexpectedly if machining is resumed under the control of that program. It is bad practice to edit (modify, insert or delete), commands from a machining program while it is in use. **Do so at your own risk!**

Safety instructions for working on electrical parts

- Work on the electrical system, e.g. connection, must only be performed by qualified technicians or electricians.
- The electrical cabinet must only be opened by authorized personnel.



WARNING: Danger of Life! Never perform work on live parts:



WARNING: Turn the 'MAIN SWITCH' to '0' and unplug the machine from the power outlet.



WARNING: Use a Digital Voltage meter and test to make sure that the circuit is dead.

- Faulty fuses must be replaced with fuses of the same amperage and type.

Safety instructions related to daily maintenance



ATTENTION: This section presents safety precautions related to daily maintenance of the IRP1200 machine. Before attempting to perform daily maintenance, read the following safety instructions related to daily maintenance carefully.



ATTENTION: Press the “**EMERGENCY STOP**” button before carrying out any maintenance work in the work chamber.



ATTENTION: Read the supplied Maintenance Manual carefully and always perform maintenance work at the required maintenance intervals. Observe all safety instructions for each task and comply with all local health and safety regulations.

Maintenance work (except cleaning) should only be performed by qualified maintenance personnel or will be carried out by a Zeeko approved service agents.

- Read all instructions for working with electrical equipment when cleaning and maintenance jobs are performed.
- The machine must be switched off when carrying out certain maintenance jobs.
- Read the instructions for each maintenance job and ensure instructions are fully adhered to.
- Use lint-free cloths when cleaning inside the work chamber and guard windows.
- After cleaning check all screwed connections for signs of leaks and ensure that they are tight. Rectify all issues immediately.
- Always correctly tighten any screwed connections which may have been loosened for maintenance or repair purposes.
- If safety devices/guards are removed for any set-up, maintenance or repair procedure, they must be remounted immediately after completion of the work. Ensure that all such devices are functioning properly.
- Always dispose of consumables and any other auxiliary substances or parts in a safe and environmentally sound manner, in line with local regulations.
- Fuse replacement - Before replacing a blown fuse it is necessary to locate and remove the cause of the blown fuse. For this reason, only personnel who have received approved safety and maintenance training may perform this work.

The machine

Machine dimensions

Attribute	Dimension
Width	2800 mm
Depth	3600 mm
Height	3000 mm
Weight	14000 kg

Axis	Maximum limit	Minimum limit
A	+270 degs	-270 degs
B	+180 degs	-180 degs
X	+650 mm	-650 mm
Y	+650 mm	-650 mm
Z	+5 mm	-495 mm
C	<p>Polishing Envelope: Parts up to \varnothing1200 mm and 430 mm height. For anything outside of these dimensions please consult Zeeko.</p> <p>Dependent on other dimensions and polishing tool path strategy, heights of 678 mm and diameters of 1600 mm are achievable.</p> <p>Max Load Capacity = 500 kg</p>	

Attribute	Accuracy
A & B axes -Maximum Rotational Velocity	10 rpm
C axis -Run-Out -Speed Range -Positional Repeatability	<5 μ m T.I.R 0 to 150 rpm (with or without the table attached) \pm 2.5 arcsecs
H axis -H axis Runout (excludes bonnet) -Rotational Speed Range	<5 μ m T.I.R 0 to 2000 rpm
X & Y axes -Straightness (Vertical & Horizontal) -Slide Positioning Error -Bi-directional Repeatability -Max Velocity -Max Acceleration	<30 μ m over full travel <5 μ m over 100 mm <50 μ m over full travel <5 μ m 3000 mm/min 250 mm/sec ²

IRP1200 MK1 – Fanuc Ballscrew

Operation Manual

Z axis	
-Z axis Straightness (Vertical & Horizontal)	<30 µm over full travel <5 µm over 100 mm
-Slide Positioning Error	<50 µm over full travel
-Bi-directional Repeatability	<5 µm
-Max Acceleration	1.25 m/sec ²
-Max Velocity	3000 mm/min
X-Y-Z Geometrical relationship	
-X/Y Circularity	<50 µm
-X/Z Circularity	<50 µm
-Y/Z Circularity	<50 µm
-X/Y Squareness	<50 µ/m
-X/Z Squareness	<50 µ/m
-Y/Z Squareness	<50 µ/m

Tool options

Tooling options	
-R20	0.01 – 0.3 mPa
-R40 (Standard)	0.01 – 0.3 mPa
-R80	0.01 – 0.3 mPa
-R160	0.01 – 0.3 mPa
-R320	0.01 – 0.05 mPa

Continuous noise level

- < 50dB (A).

Power supply

The machine is designed for operation on a 3-Phase, 4 Wire (i.e. 3 Phases + Earth). The machine will be preset to the mains voltage stated at the time of order. The standard is:

- 400 v/50/60 *Hz: 3-PE \pm 5 %.



WARNING: The machinery must only be plugged into a socket which has a protective earthed conductor. The primary side must match the incoming customer supply voltage. If a supply transformer is required, the secondary voltage supply to the machine must match the machine voltage specification.



WARNING: If the mains voltage supply is not the same as that specified on the machine rating plate, the transformer tapplings (if applicable) must be interchanged to correspond with the existing mains voltage. **This MUST only be performed by qualified personnel.**

Compressed air supply

Compressed air supply	
Minimum Input Pressure	6 bar
Maximum Input Pressure	8 bar
C axis purge value	1 bar
H axis purge value	1 bar

Machine assemblies

Machine overview

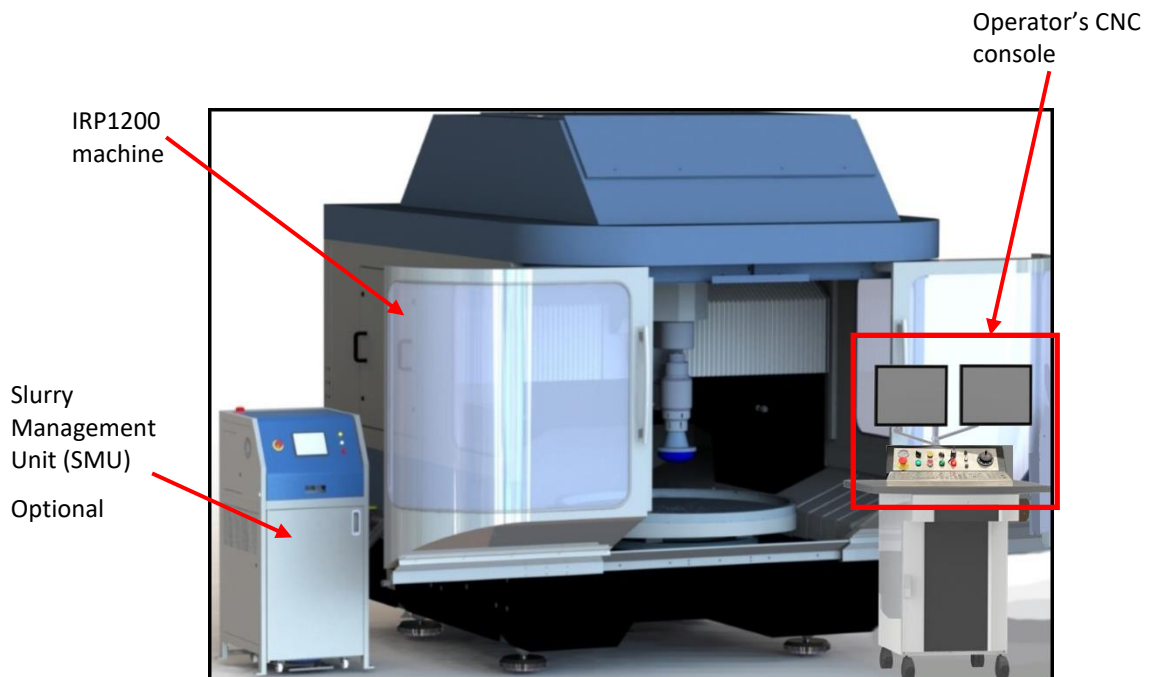
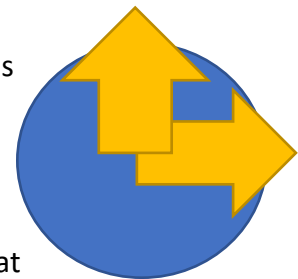

Figure 1 - Machine Assembly

Definitions of axes

Rotating a rotary axis indicates it is in axis mode, spinning a rotary axis indicates it is in spindle mode.

When defining positions using the work piece, it is assumed to be a standard 100 mm diameter pass-off part and it is viewed head-on (i.e. along the C axis onto the surface to be processed) and straight (i.e. without tilting of the head). In the case of a vertical C axis the viewer is assumed to be standing at the front of the machine, bending over to view the C axis from above.



Each statement below starts with the tool spindle parallel with the C axis (with the VP arm to the back of the machine in case of a Type 2 VP) and the tool just touching the work piece at its centre:

- Moving the X axis in the +ve direction positions the tool on the right side of the work piece.
- Moving the Y axis in the +ve direction positions the tool on the top side of the work piece.

- Moving the Z axis in the +ve direction moves the tool away from the work piece.
- Rotating the C axis in the +ve direction rotates the work piece clockwise.
- Mx3 spins the work piece clockwise.
- Mx3 spins the tool synchronous with the clockwise spinning work piece, when touching it.
- Rotating the H axis (if the machine is capable) in the +ve direction rotates the tool in the same direction as Mx3.

For a “Type 1” VP machine

- Rotating the A axis in the +ve direction tilts the back of the tool spindle to the left of the work piece.
- Rotating the B axis in the +ve direction tilts the back of the tool spindle to the top of the work piece.

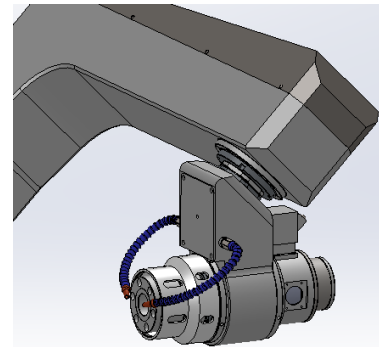

For a “Type 2” VP machine

- Rotating the A axis in the +ve direction rotates the VP arm to the left of the work piece.
- Rotating the B axis in the +ve direction tilts the back of the tool spindle to the left of the work piece.

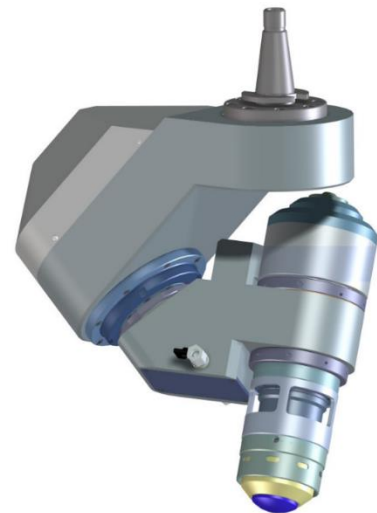

Sign conventions for “Type 2” virtual pivot

Vertical C axis (IRP1200 Mk1)

X axis motions



-600 mm

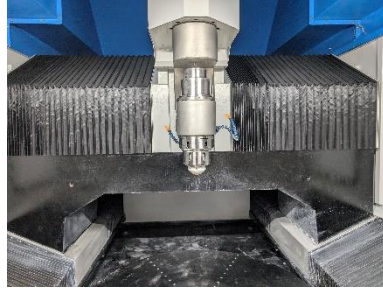

0 mm

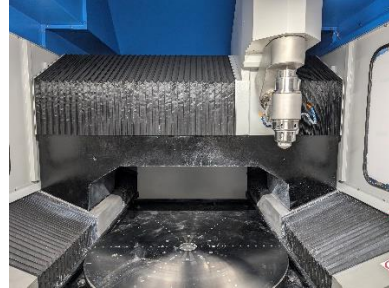

+600 mm

Y axis motions



-600 mm

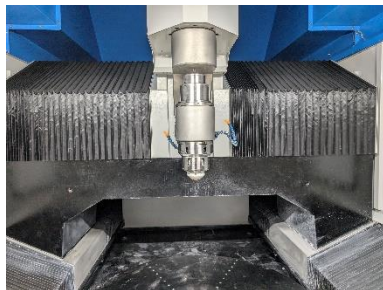

0 mm



+600 mm

A axis motions

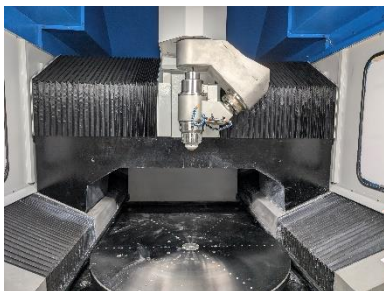

-90 mm

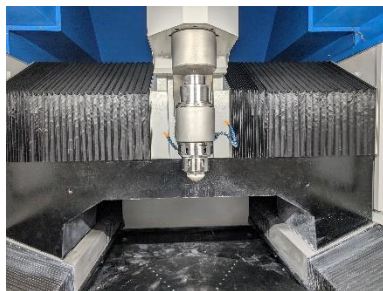

0 mm

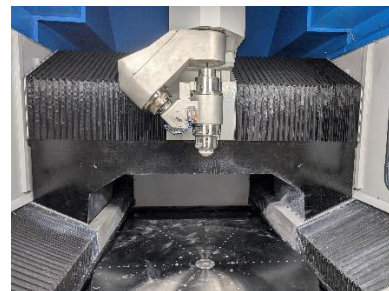

+90 mm

B axis motions



-90 mm



0 mm

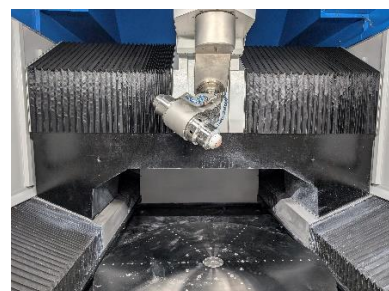

+90 mm

Figure 2: Motions of the B axis

Z axis motions

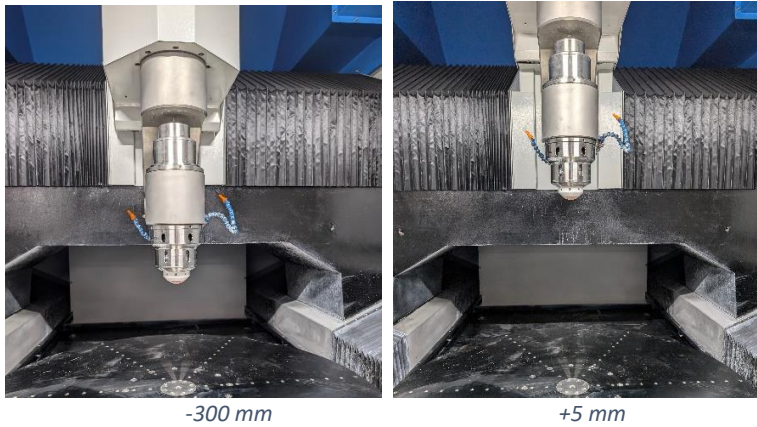
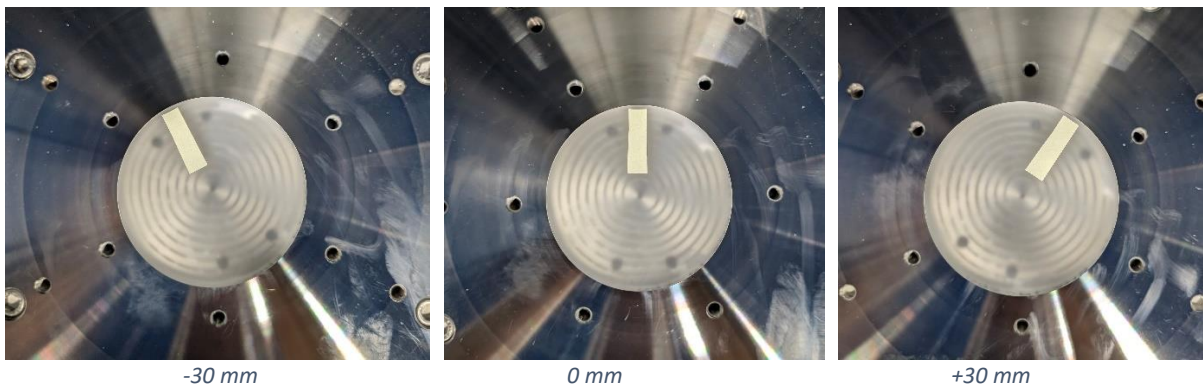
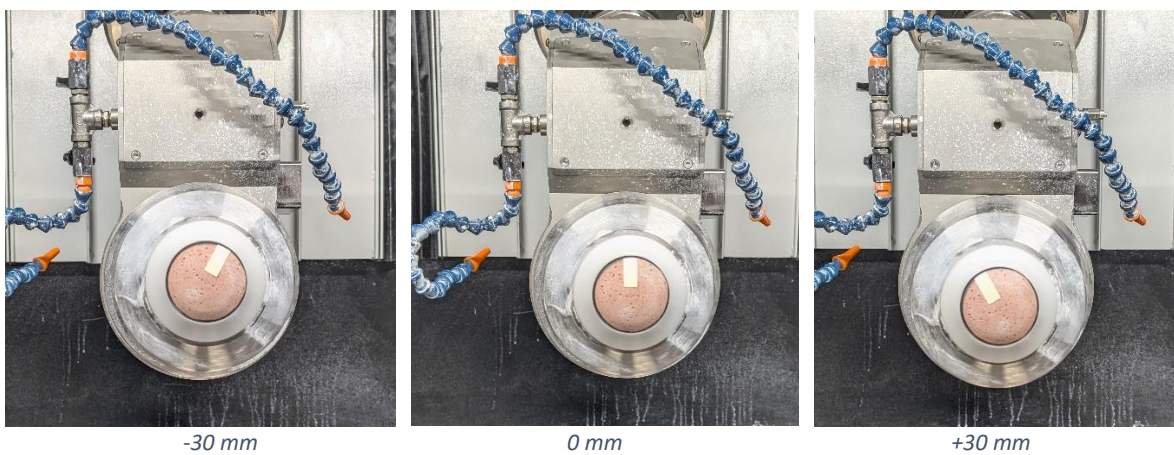

Figure 3: Motions of the B axis

C axis (Spindle and Axis modes)



H axis (Spindle and Axis modes)



Pneumatic cabinet and switchgear cabinet

The air service unit is located at the top rear of the machine. The CNC controls and switchgear are located at the bottom rear of the machine, See *Figure 4 - Pneumatic cabinet and switchgear cabinet*.

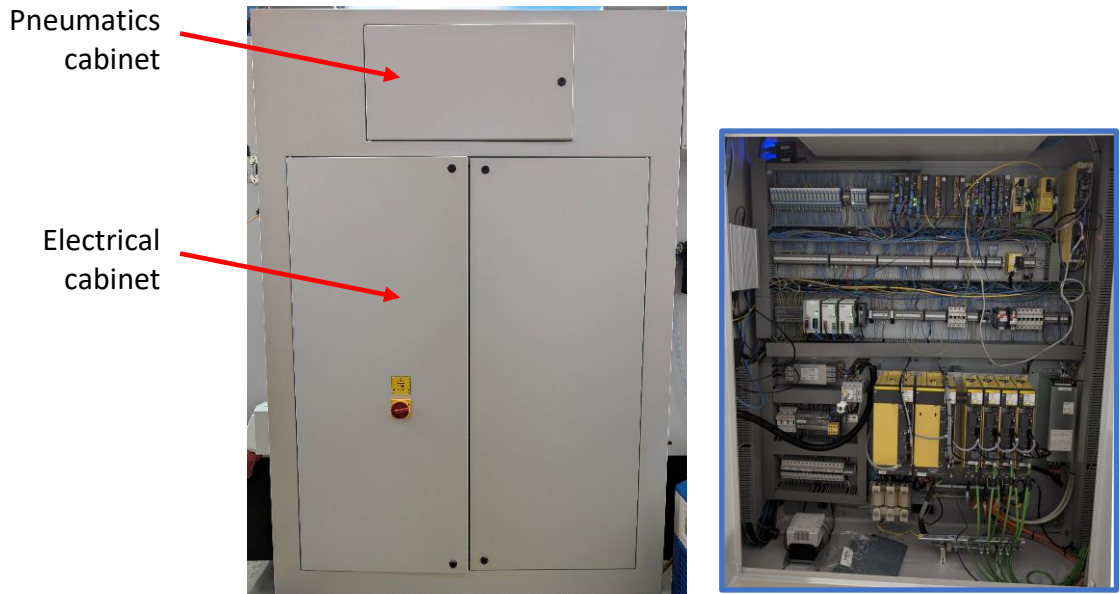

Figure 4 - Pneumatic cabinet and switchgear cabinet

Pneumatics controls

The pneumatic controls are preset at the time of installation and should not require operator adjustment, other than routine maintenance and periodic checks. Should an inspection or adjustment be required, access can be gained by using an M10 (8 mm) hexagon key and unlocking the access door. See (*Figure 5 - Pneumatic Controls*).



Figure 5 - Pneumatic Controls

CNC control panel

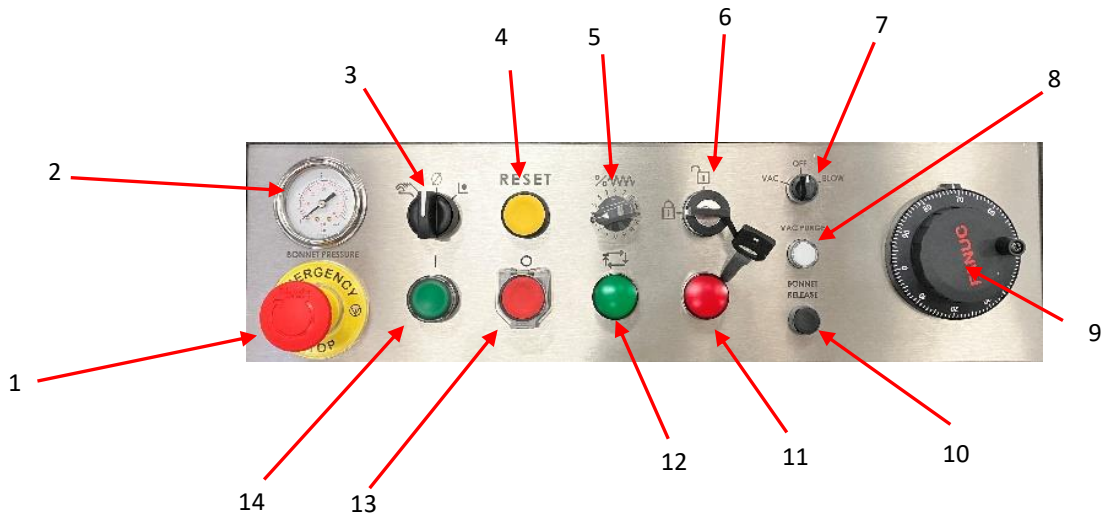
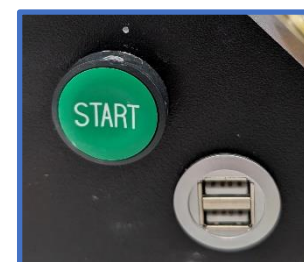
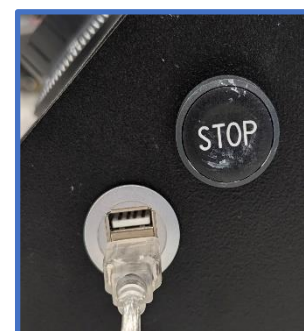

Figure 6 - CNC Control Panel

#	Description	#	Description
1	“EMERGENCY STOP” button	8	“Purge” button
2	Analogue head (Bonnet) pressure gauge	9	“Manual Pulse Generator” (MPG) hand wheel
3	“AUTO-MANUAL” CNC mode switch	10	“Bonnet” release
4	CNC “RESET” button	11	“Fault” lamp
5	“Feed Rate” override switch	12	CNC “In-Cycle” lamp
6	“Operator Program Lock” switch	13	CNC “Drives Power OFF”
7	“Vac / Blow” selector	14	CNC “Drives Power ON”

Table 2 - CNC Control Panel Table

The USB Sockets are located on both sides of the Operators CNC control panel. These are used to transfer data (programs) to and from the machine and plugging in USB devices such as keyboards. There are also STOP and START cycle buttons located on each side of the CNC control panel, START is located on the left-hand side and STOP is located on the right-hand side.



Operating modes

Manual mode

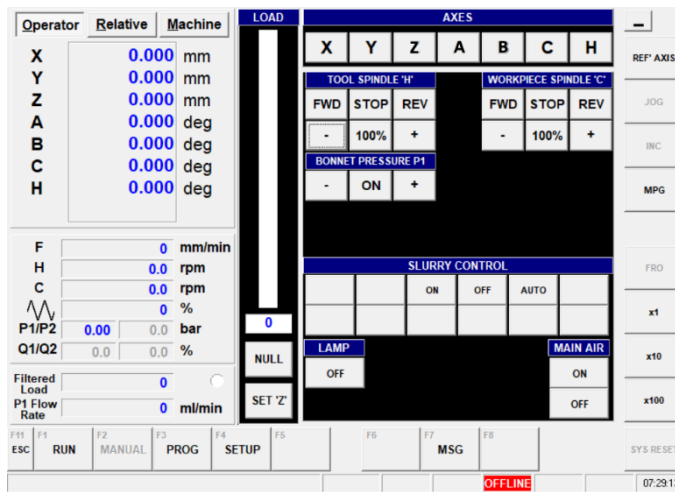

Figure 7 - GUI - Manual mode



Figure 8 - Axis selection

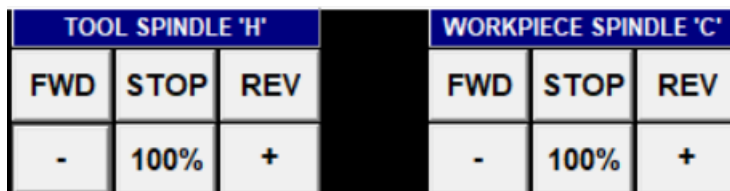

Figure 9 - SPINDLE selection

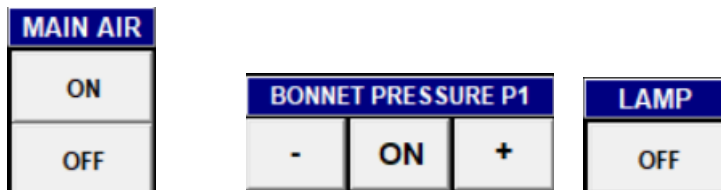

Figure 10 - MAIN AIR, BONNET PRESSURE and LAMP control

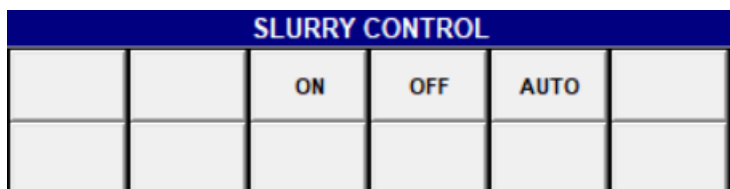

Figure 11 - Slurry control

Switching ON and OFF the machine

Switching ON the machine

1. To switch on the machine, turn the power on at the rear of the machine by turning the “Main” switch 90 ° (degrees) clockwise.



The machine powers on and windows loads up and requires a password to log in.

2. Enter the password provided by Zeeko. **Zeek0** We recommend that you change this password.
3. On the control panel, press the CNC “Drives ON” switch. See (Figure 13 - CNC Drives ON switch).



Figure 12 - CNC Drives ON switch

Allow a short period of time to elapse (up to 1 minute) while the PC auto boots. The screen becomes active and the CNC initiates, eventually the Zeeko GUI Software and the Fanuc software Auto Load and the following “Zeeko GUI” screen appears. **Please minimize the “Fanuc GUI” screen (if it is not automatically minimised).**

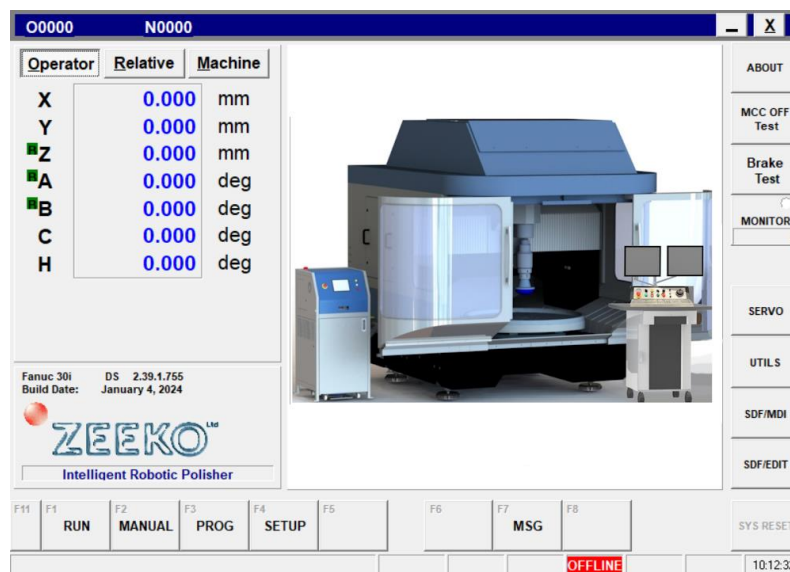

Figure 13 - Zeeko GUI Main Menu

- Making sure that all the doors are fully closed, if on start up the “EMERGENCY STOP” button is not pressed in, the operator must press the “EMERGENCY STOP” button, then release it before pressing the reset button. Now press the “RESET” button.



- Once the “RESET” button has been pressed, perform a MCC by pressing the “MCC OFF Test” button.



An **MCC off Test** of the safe stop function monitors the contact state of the electromagnetic contactor (MCC), compares the state with a command to the electromagnetic contactor, and checks that the safe stop function works normally. The Operator must carry out the test.

This test must be carried out when the CNC is turned on or when 24 hours have elapsed after the previous test is completed. If the CNC is turned on or if 24 hours have elapsed after the previous test is completed, a guard open request (protective door open request) should not be accepted until the test is performed.

The machine runs through a series of background tests on all the axes which are visible in the “Zeeko GUI” screen, represented by green icons at the side of each axis.

Operator	Relative	Machine
X	0.000	mm
Y	0.000	mm
Z	0.000	mm
A	0.000	deg
B	0.000	deg
C	0.000	deg
H	0.000	deg

Display during MCC OFF Test

Operator	Relative	Machine
X	0.000	mm
Y	0.000	mm
Z	0.000	mm
A	0.000	deg
B	0.000	deg
C	0.000	deg
H	0.000	deg

Display after MCC OFF Test completed



ATTENTION: Once the compressed air supply has been switched on, the machine is fully active. Before running any CNC Toolpaths, please ensure that the A&B axes are correctly referenced before proceeding. [See Referencing A&B axes.](#)



NOTE: If when the 24 hours are up and a job is still running, the job will continue to run until it has completed. Once completed you **must** run the “MCC OFF Test”!

Referencing A&B Axes

- To reference the A and B axis, each axis needs to be moved to the +VE side of the machine.



TIP: Programs are only active when the machine’s “AUTO-MANUAL” CNC Mode switch is set to “Auto/Cycle” mode.

1. If the “EMERGENCY STOP” button is not pressed, press the “EMERGENCY STOP” button, then release it again and press the “RESET” button on the control panel.
2. Select the “REF' AXES” button as shown in *Figure 15 - Manually position A & B axes.*

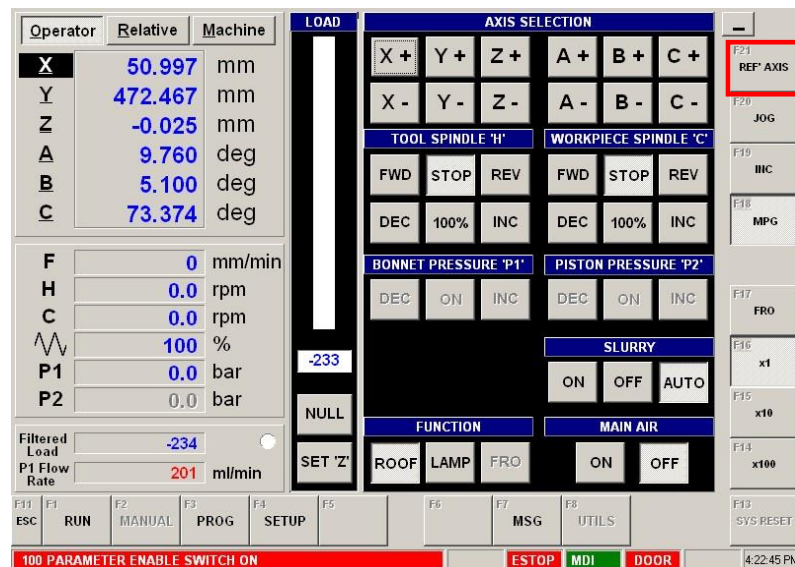

Figure 14 - Manually position A & B axes

The “REFERENCE AXIS” screen displays. See (Figure 15 - Reference axes).

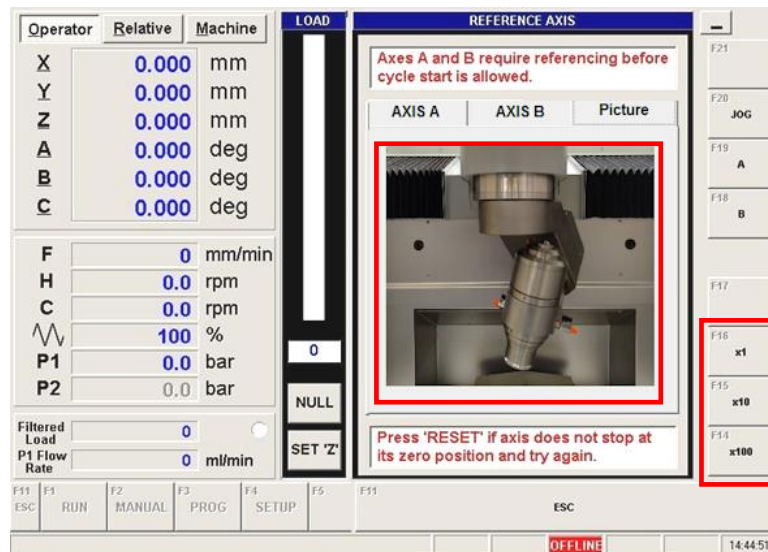

Figure 15 - Reference axes

3. Move both “AXIS A” and “AXIS B” to the position shown in the picture, by selecting the “MPG” button followed by either the “A” or “B” axis buttons and using the x1, x10 or x100 micron buttons and turning the “MPG” hand wheel accordingly. See (Figure 15 - Reference axes).
4. Once the axes are positioned as requested, press the “MREF” button and then press the “AXIS A” tab page and then click the “A” button. The machine will move the A axis in the correct direction until it detects the reference position. This may take up to 1 minute depending on the distance to be travelled. **Please keep your hand close to the “EMERGENCY STOP” button, just in case the axis continues past the correct reference point.**
5. When complete and the MACHINE POSITION displays 0.000 mm for the A axis, now perform the same operation for the B Axis. See (Figure 16 - Reference axis A).

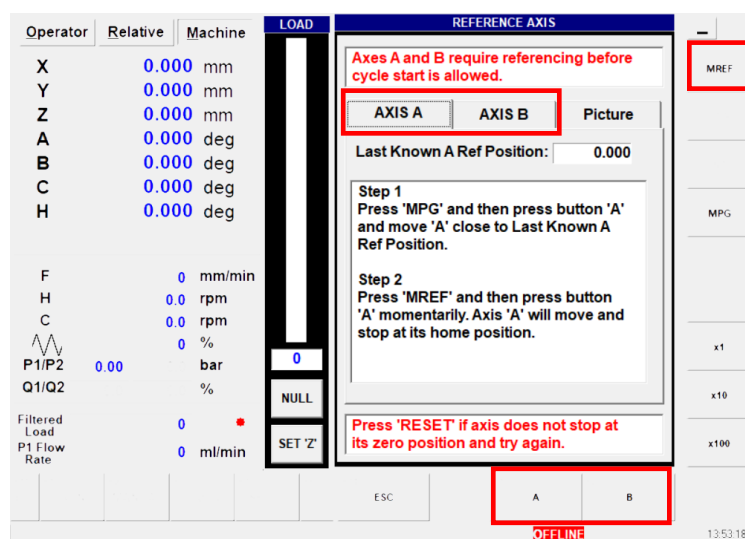

Figure 16 - Reference axis A



NOTE: The Operator Positions will show a value other than 0.000 mm depending on the offsets between the transducer and true Zero. These values will not be updated to 0.000 mm until a HOME move or other CNC controlled move is actioned.

When complete and the MACHINE POSITION displays 0.000 mm for the B axis it is necessary to perform a HOME move from the “RUN” page to fully zero the mechanical positions of the A&B axes.

6. Once A and B have been referenced, select “ESC” then “RUN”. Ensure the “CNC Mode” switch is in auto mode and select the “HOME” program and push the Start button. The A and B axes should now look like... *Figure 17 - A and B axis both referenced.*



Figure 17 - A and B axis both referenced

Switching on the compressed air supply

1. Ensure that the main air supply is switched on at the supply and turn the air supply isolator valve to the ON position.



Main compressed air
isolator valve to the
machine (ON position)

- Switching on the compressed air (Main Air) supply to the machine, is activated from the “Manual” menu in the “Zeeko GUI”. This is done by pressing the “Manual” button from the main screen and then pressing the “ON” button for the main air. See (Figure 18 - Manual button on main screen) and see (Figure 19 - Compressed Air ON).

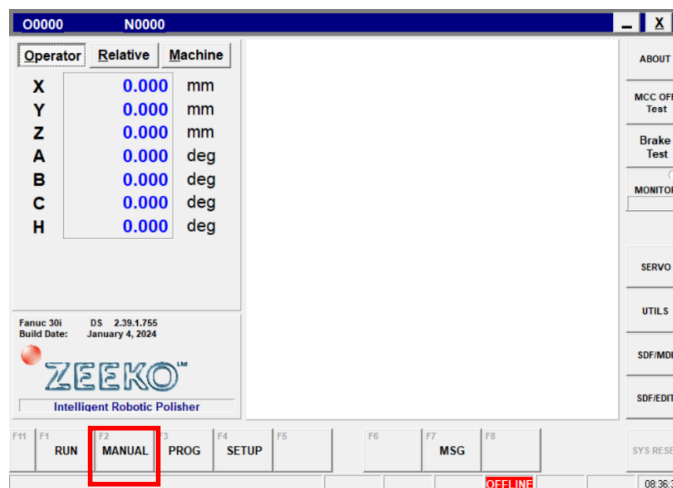

Figure 18 - Manual button on main screen

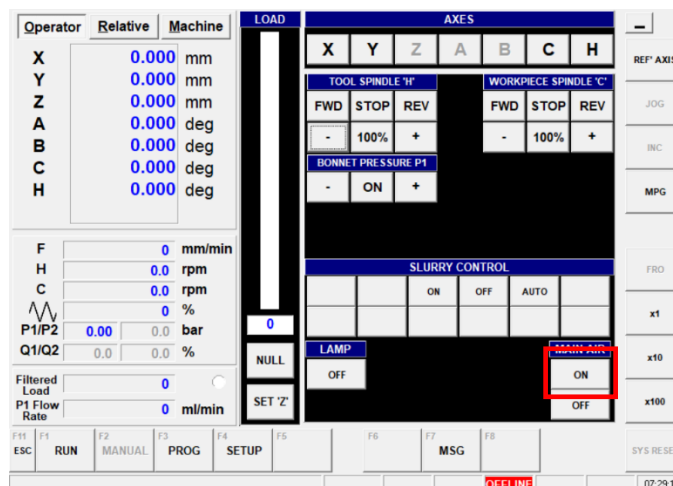

Figure 19 - Compressed Air ON

Switching off and disconnecting the compressed air supply

- Switching off the compressed air (Main Air) supply to the machine, is activated from the “Manual” menu in the Zeeko GUI. This is done by pressing the “Manual button” from the main screen and then pressing the OFF button for the main air. See (Figure 20 - Compressed air supply OFF).

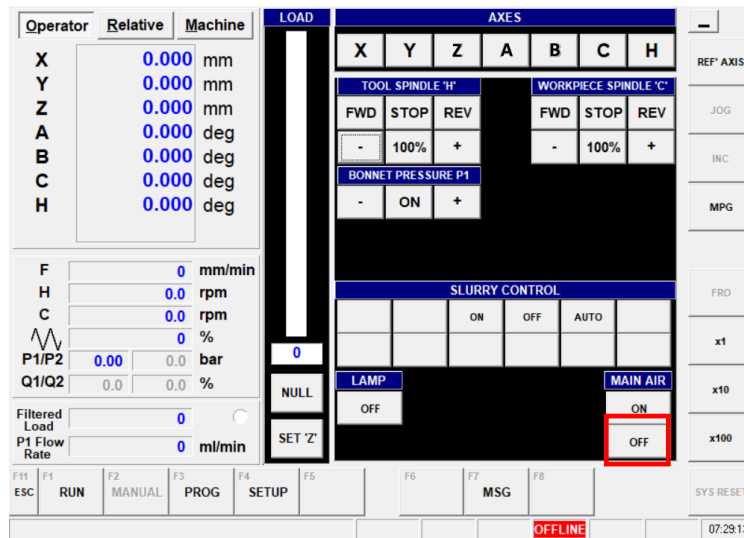

Figure 20 - Compressed air supply OFF

- Turn the compressed air supply isolator valve to the “OFF” position.

Main compressed air isolator valve to the machine (OFF position)



- Disconnect the main air supply from the machine’s air supply feed pipe.



Opening/Closing the roof

1. Opening or closing of the roof on top of the machine, is activated from the “Manual” menu see (done by pressing the “Manual” button from the main screen and then pressing the “Roof” button).



NOTE: If the machine doesn't have an automatic roof, the function is not available in the “Zeeko GUI”.

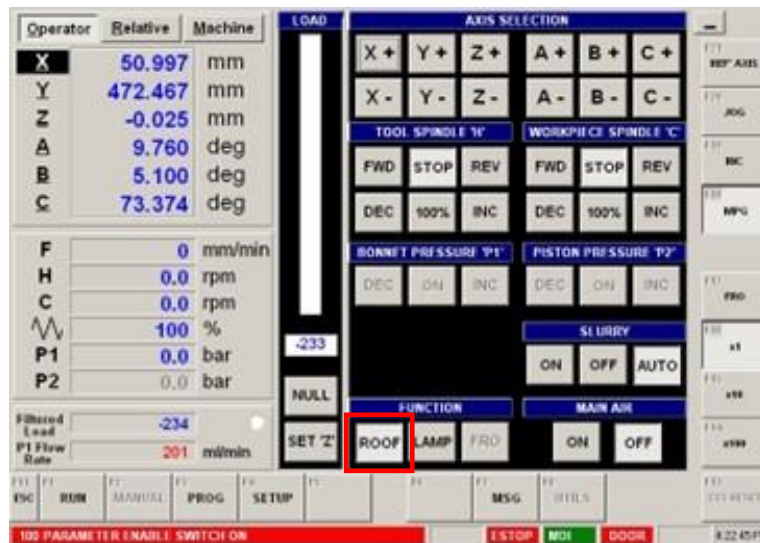

Figure 21 - Activating the roof (Open/Close)

Switching off the machine



ATTENTION: Please ensure you follow the correct shut-down procedure to avoid any potential issues with the software during or after the start-up process.

2. Press the “AIR OFF” and “LAMP OFF” buttons in the “Zeeko GUI”. See
3. Figure 22 – AIR OFF – LAMP OFF.

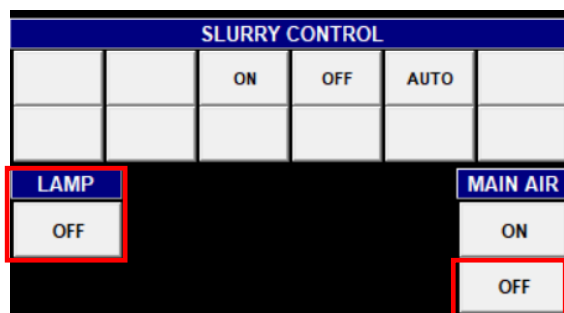

Figure 22 – AIR OFF – LAMP OFF

- Press “ESC” to return to the “MAIN” menu and then press the “X” symbol in the top right corner of the “Zeeko GUI” screen to close out of the “Zeeko GUI”.



The “Confirm Exit” dialog box opens.

- Click OK.
- Use the same “X” symbol to exit all other open screens. Then exit windows in the normal way.

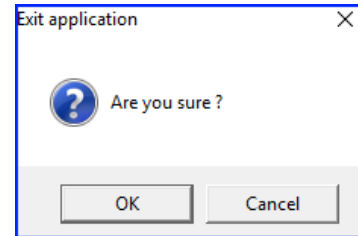

- Press the “CNC Drives Stop” button and press the “EMERGENCY STOP” button.



The “NCBOOT32” dialog box opens. See (Figure 23 - NCBOOT32 dialog Box).

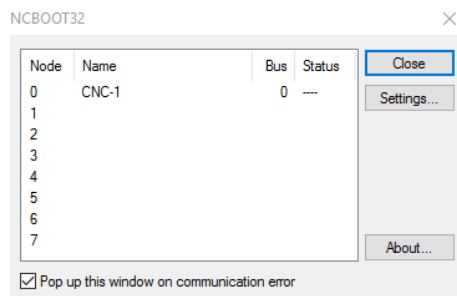

Figure 23 - NCBOOT32 dialog Box

- Click “Close” to exit the application.



TIP: During the shutdown process of the machine, there will be no special indication on the screen. Please be patient.

Switching off the compressed air supply

The MAINS air within the machine (i.e. Purges, Head Pressure etc.) will automatically turn-off when power is removed from the machine, however it is good practice to also remove the mains air to the machine if the machine is to be left standing for long periods of time.

Switching off the electricity at the “MAIN SWITCH”

When Windows has shut down, turn off the master “MAIN SWITCH” (main isolator switch) at the rear of the machine by turning the switch 90 ° anticlockwise.



Using “Canned” programs

Canned programs description

- A variety of pre-defined CNC programs are available to the Operator from the “RUN” page: See (Figure 24 - Main screen - Run option).

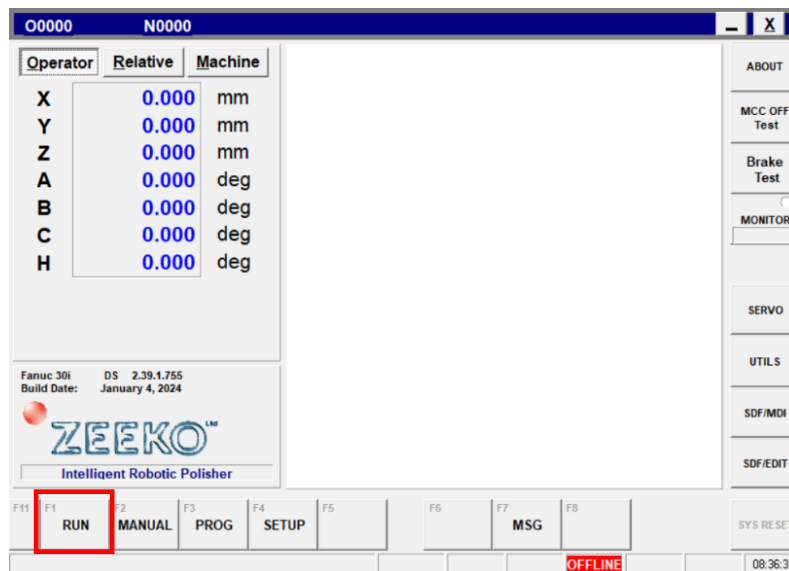

Figure 24 - Main screen - Run option

1. Press the “RUN” button from the main “Zeeko GUI” screen.

The screen changes to display the list of “Canned” programs. See (Figure 25 - Canned programs).



TIP: Programs are only active when the machine’s “AUTO-MANUAL CNC” mode switch is set to “Auto/Cycle” mode.

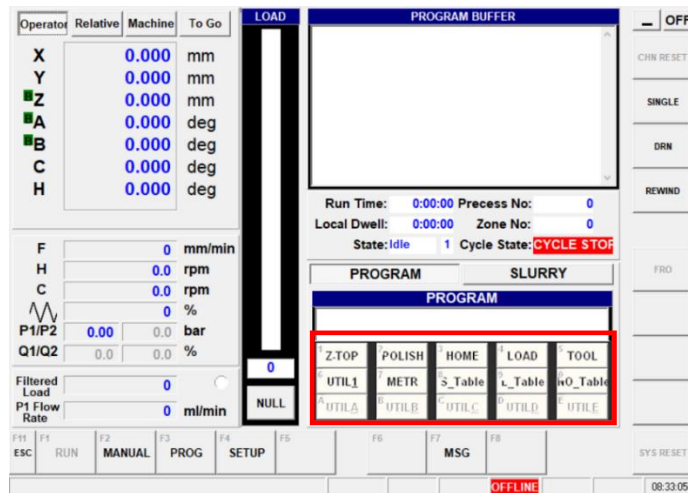

Figure 25 - Canned programs

These programs are text-based programs and can be loaded directly by the operator without the need for deleting or changing the primary CNC program. Simply selecting the desired program option causes the program to be temporarily loaded into memory. When the “CYCLE START” button is pressed (located on the Left side of the control panel), the program Initiates. On successful completion the canned CNC program is automatically removed from temporary memory and the dummy CNC program loads.



Setting up a utilities program

Operators can define the “Utility” button to call for a particular canned program according to their requirement.

1. Insert your USB Pen Drive into the USB slot on the panel and in the windows environment, save the required program (ensuring that the program has the extension .txt) in directory D:/Cncfiles/.
2. Open the” Program Transfer Tool” (located on the Windows taskbar).

The “Program Transfer Tool” window opens. See (Figure 26 - Program Transfer Tool window).

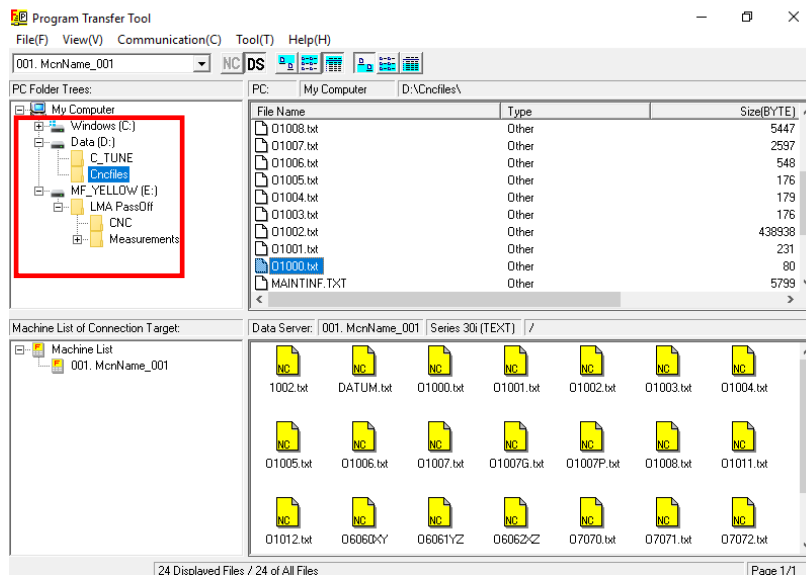

Figure 26 - Program Transfer Tool window

3. Navigate to the D:/Cncfiles directory.
4. Drag and drop the required file from the local window (top window) to the data server window (bottom window), Alternatively you can Right-click on the required file and select “Download” from the pop-out menu.

The “Download Program” dialog box opens. See (Figure 27 - Download Program dialog box).

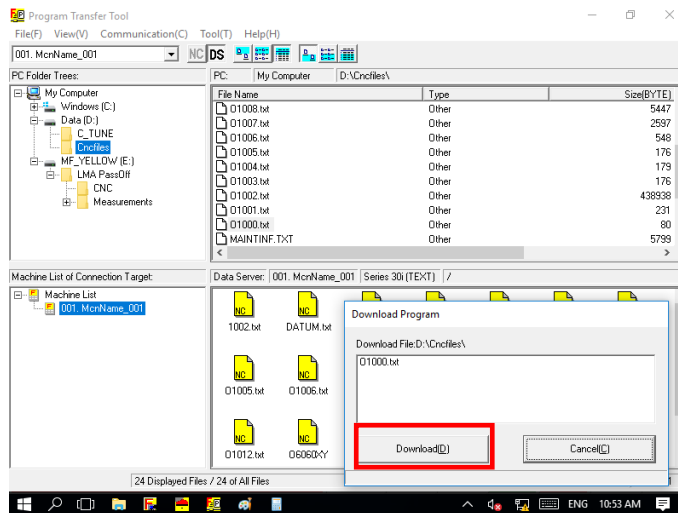

Figure 27 - Download Program dialog box

5. Click Download(D).

You may get a warning stating that a file with the same file name may exist in the program buffer and if the CNC parameters set allow overwriting, then click “Yes”, this will allow the existing file to be overwritten. See (Figure 28 - Download Program – Warning). If overwriting is not

permitted in the CNC parameters, then an “Error” dialog box appears. See (*Figure 29 - Fail to download*).

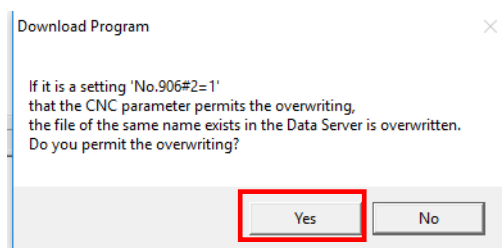

Figure 28 - Download Program – Warning

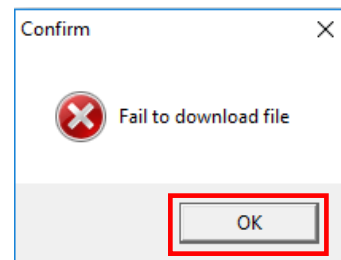

Figure 29 - Fail to download

6. Press “OK” to close the dialog box.
7. Go back to the Zeeko GUI main screen and you will see the duplicate program displayed in the “Program Buffer” window. See (Figure 30 - Program Buffer window).

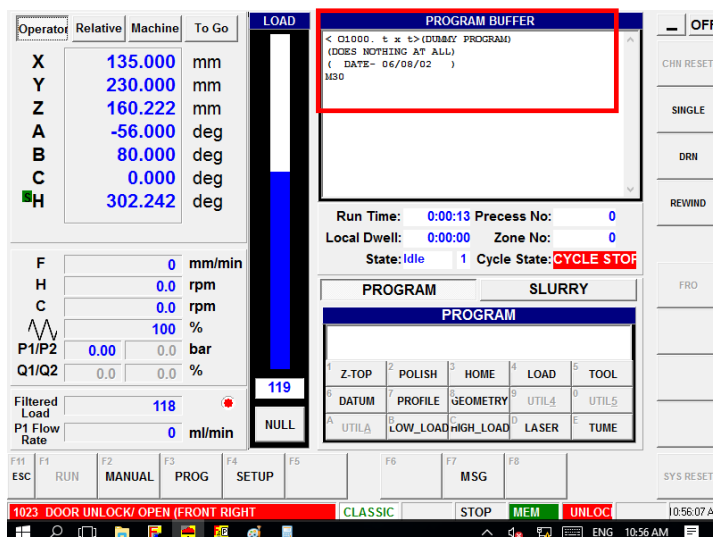

Figure 30 - Program Buffer window

8. Select a different Canned program to clear the current program and repeat the above steps to transfer the program. See (Figure 27 - Download Program dialog box).
9. Press the “Setup” button. See (Figure 31 - Main GUI screen - Setup).
10. Press “MSD” button. See (Figure 32 - Setting up a utilities program).
11. Select “File Names” tab page. See (Figure 32 - Setting up a utilities program).
12. Change the name of the “Utility” button (if required) by editing the text in the text box window and rename it as required.
13. Select the program from the list.
14. Press “Save” button once completed.

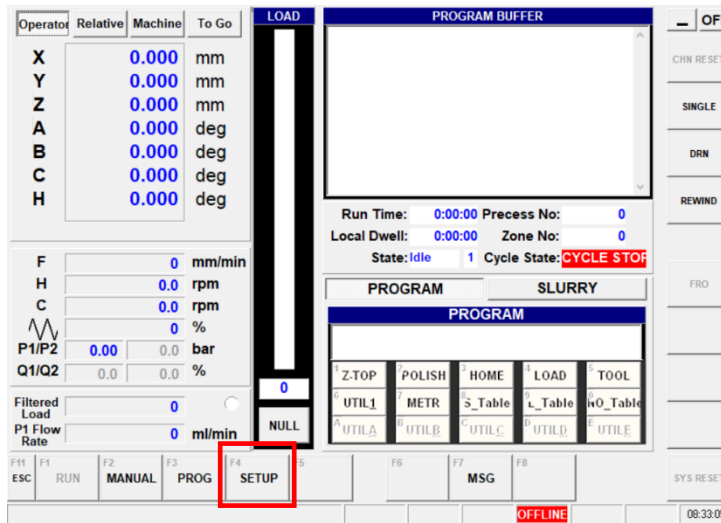

Figure 31 - Main GUI screen - Setup

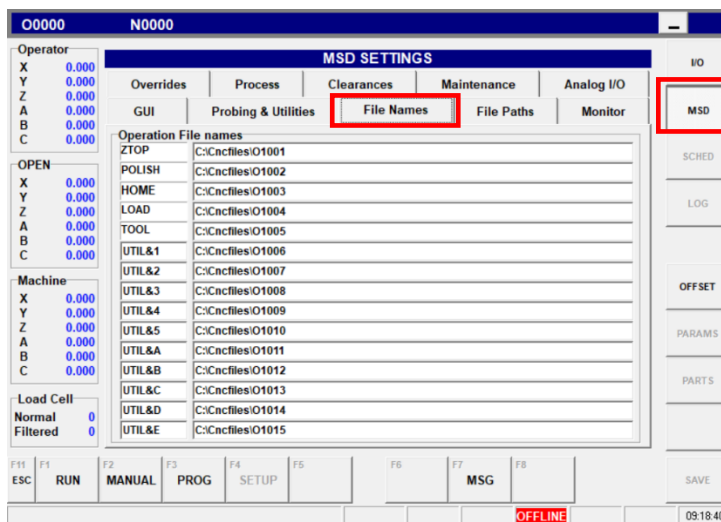

Figure 32 - Setting up a utilities program

Using the Program Transfer Tool

Setting up a program

Operators can define the “Utility” button to call for a particular program according to their requirement.

1. Insert your USB Pen Drive into the USB slot on the panel and in the windows environment save the required program (ensuring that the program has the extension .txt) in directory D:/Cncfiles/.
2. Open the “Program Transfer Tool” (located on the Windows taskbar).

The “Program Transfer Tool” window appears. See (Figure 33 - Program Transfer Tool window).

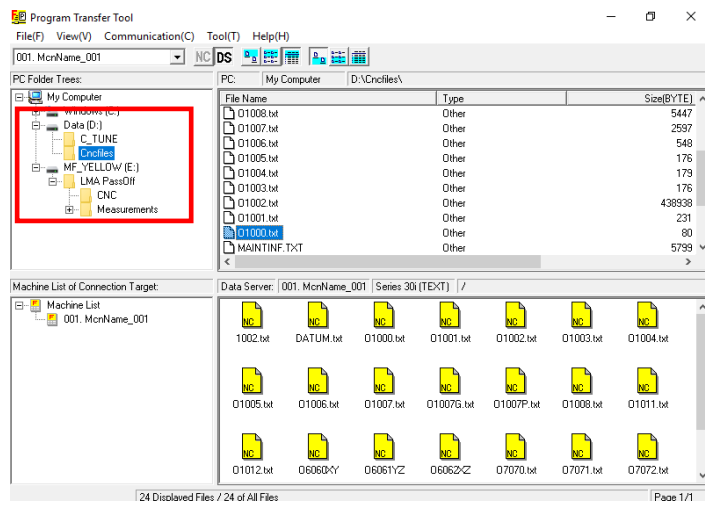

Figure 33 - Program Transfer Tool window

3. Navigate to the D:/Cncfiles directory.
4. Drag and drop the required file from the local window (top window) to the data server window (bottom window), Alternatively you can Right-click on the required file and select “Download” from the pop-out menu.

The “Download Program” dialog box opens. See (Figure 34 - Download Program dialog box).

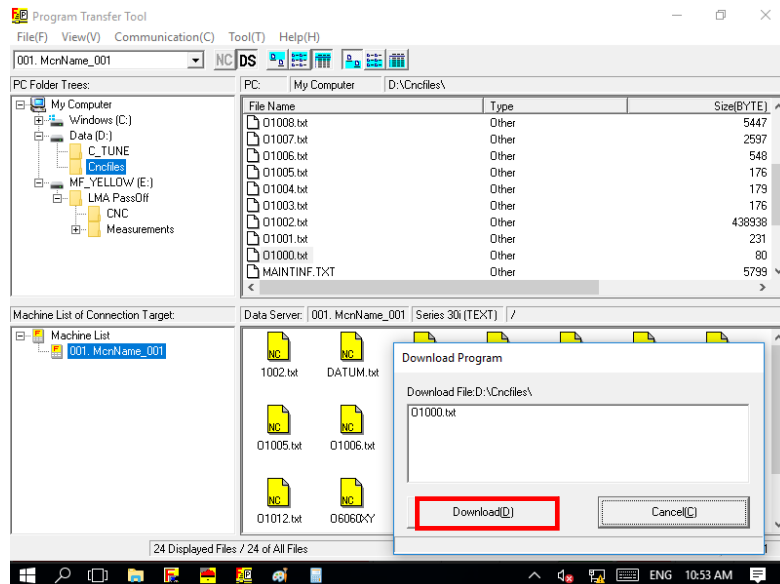

Figure 34 - Download Program dialog box

5. Click Download(D).

You may get a warning stating that a file with the same file name may exist in the program buffer and if the CNC parameters set allow overwriting, then click “Yes”, this will allow the existing file to be overwritten. See (Figure 35 - Download Program – Warning). If overwriting is not permitted in the CNC parameters, then an “Error” dialog box appears. See (Figure 36 - Fail to download).

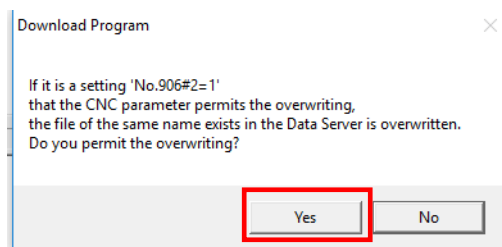

Figure 35 - Download Program – Warning

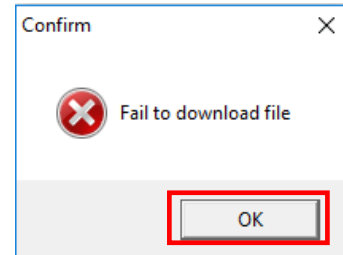

Figure 36 - Fail to download

6. Press “OK” to close the dialog box.
7. Go back to the Zeeko GUI main screen and you will see the duplicate program displayed in the “PROGRAM BUFFER” window. See (Figure 37 - Program Buffer window).

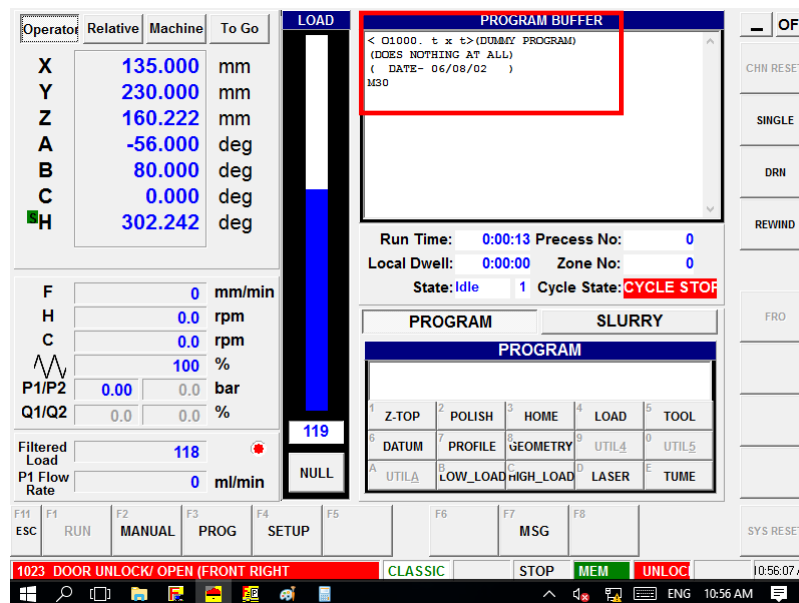

Figure 37 - Program Buffer window

8. Press the “Home” button to clear the program and repeat the above steps to transfer the program. See (Figure 37 - Program Buffer window).
9. Press the “Setup” button. See (Figure 38 - Main GUI screen - Setup).
10. Press “MSD” Button. See (Figure 39 - Setting up a utilities program).
11. Select “File Names” Tab page. See (Figure 39 - Setting up a utilities program).

12. Change the name of the “Utility” Button (if required) by selecting the file in the first column window and rename it as required.
13. Browse for the program saved in D:/Cncfiles/.
14. Press “Save” button once completed.

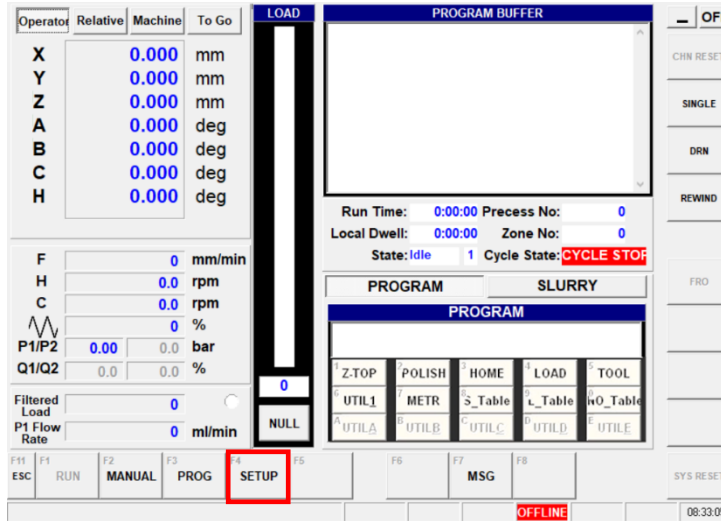

Figure 38 - Main GUI screen - Setup

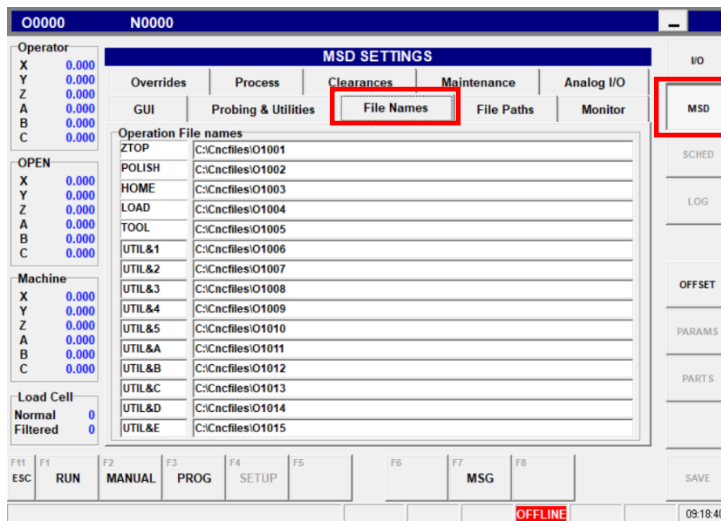

Figure 39 - Setting up a utilities program



NOTE: Please ensure you follow the correct naming conventions when saving a file, i.e. for Polishing use O1002.txt

When the file is loaded, always check the date and time is correct before running the cycle. See (Figure 40 - Checking date and time).

IRP1200 MK1 – Fanuc Ballscrew Operation Manual

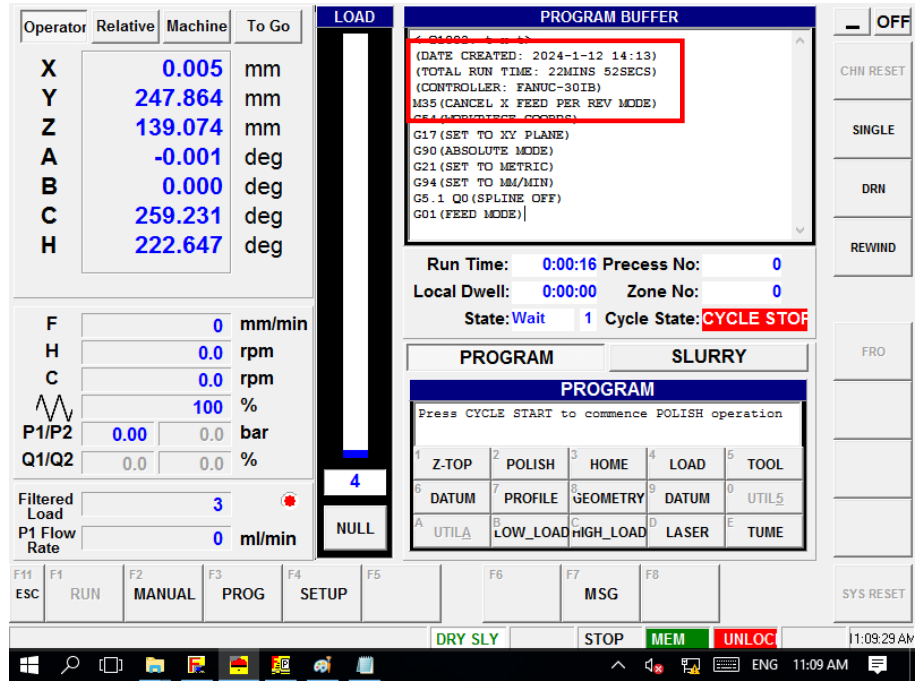

Figure 40 - Checking date and time

Setting a work piece co-ordinate system (G54)

ZTOP



NOTE: To run the machine in either “Manual” mode or “Run” mode you must turn the “AUTO-MANUAL” CNC mode switch, located on the control panel, accordingly.



AU
TO

If the Home position has been nominally set with X&Y at 0-0 then use the canned “HOME” program on the GUI “RUN” page to position the two references nominally to co-axial.

1. Exit the “RUN” page and enter the “MANUAL” page from the GUI ‘MAIN’ menu.
2. Use the Z axis “MPG” control on the control panel to move to Z axis until a small gap of around 0.25 mm exists between the tool and the work piece. See *Figure 42 - Z-AXIS gap* and *Figure 42 - MPG control wheel*.

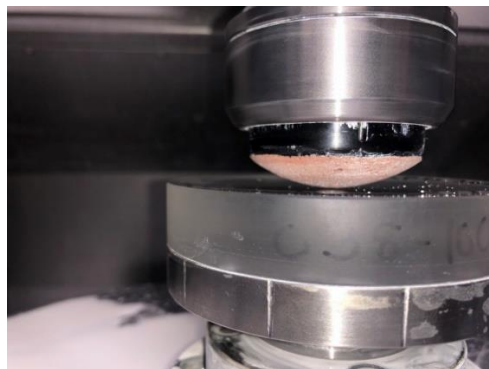

Figure 42 - Z-AXIS gap



Figure 41 - MPG control wheel

3. Exit the “MANUAL” page by pressing the “RUN” button and enter the GUI “PRO” page.
4. Select the “ZTOP” canned program and press “Start” to run the CNC program.
5. Make sure that the “AUTO” option has been selected.
6. Exit the “RUN” page by pressing the “PROG” button.
7. Exit the “PROG” page (by pressing the “ESC” button) and enter the GUI “RUN” page (by pressing the “RUN” button) at the bottom of the GUI screen. See (*Figure 43 - ESC and RUN buttons*).



TIP: As both reference surfaces are solid, take care when manually moving the Z axis.



Figure 43 - ESC and RUN buttons

8. Wait for the 5 values to appear in the “OFFSET VALUES” window (#100 to #104).
9. Review each of the 5 touch-on values and determine the desired average value for touch-on.
10. Select the value which will then appear in the “OPERATOR Z=0” window and press the “SET” button to update the “G54 Z OFFSET” value. See (Figure 44 - ZTOP select screen).

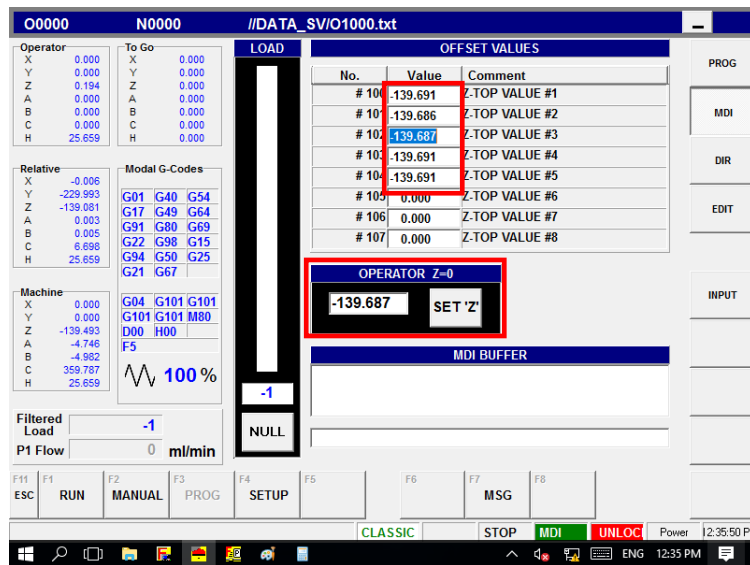

Figure 44 - ZTOP select screen

The machine co-ordinate system is now set in such a way that the Z=0 mm is the contact point between the work piece and the polishing head.



NOTE: DO NOT switch modes (e.g. PROG, MDI, DIR, EDIT or INPUT) while the Touch-On program is running. If any of these options are selected the program execution will be suspended. It can be re-started by returning to the “RUN” page and pressing “CYCLE START”.

Manual offset setting

Zeeko provides the facility to the operator so that offset to all axes can be decided by the operator to suit various process requirements.

1. Select the “Setup” button.
2. Select the “OFFSET” button.
3. Enter the offset value to the desired axis.
4. Select “Save”.



NOTE: Global coordinates are used to set VP offsets for machine zeros.

DO NOT alter global coordinates and remember to have the correct G# in the software used to generate CNC programs.

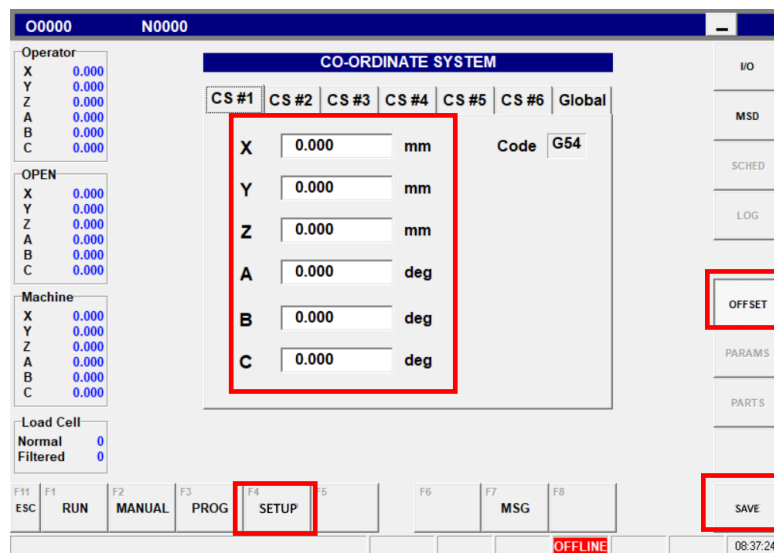

Figure 45 - Manual offset screen

Manual control of machine axes

The machine can be manually controlled in three different ways:

- Entering and actioning “G code” commands in “MDI” mode. See (Figure 47 - MDI Mode Screen).
- Using the basic manual mode (MPG).
- Using Tool Spindle and Work Spindle commands.

MDI mode

In “MDI” mode, “G code” commands can be manually entered and actioned.

1. Select the “PROG” tab button in the GUI “Main” menu.
2. Select the “MDI” tab button. *See Figure 47 - MDI mode screen.*

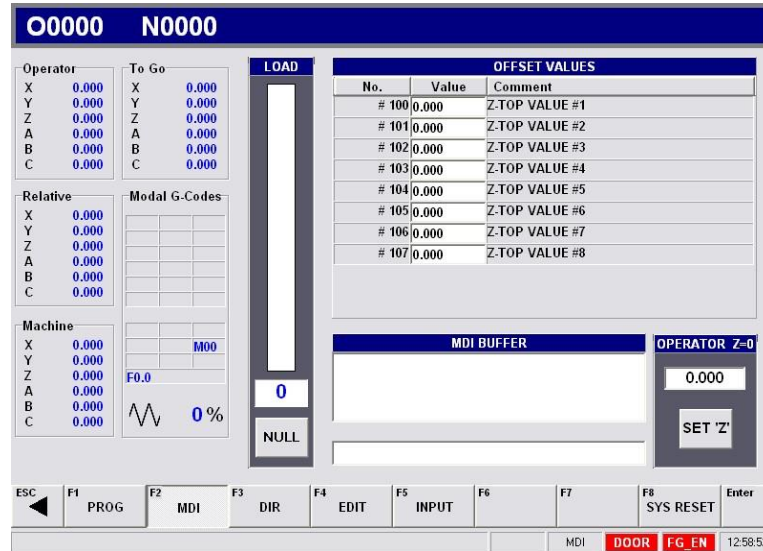

Figure 46 - MDI mode screen

3. Enter a G code command in the “COMMAND LINE” followed by pressing “ENTER” (Return) on the keyboard. The command as typed (less redundant spaces) is displayed in the “MDI BUFFER”.



TIP: In case the command does not appear in the “MDI BUFFER”.

Press the “EDIT” followed by the “MDI” tab buttons and re-enter G code command in the “COMMAND LINE” followed by “ENTER”.

4. Press the “CYCLE START” button on the Left-side of the CNC control panel.

H axis in spindle configuration

To operate the H axis in Spindle Configuration using “MDI” mode, use the following command:

- M03 S_____ (For clockwise rotation)
- M04 S_____ (For anticlockwise rotation)
- M05 (Stop rotation)

Where S_____ is where the desired revolutions per minute (rpm) is to be entered (e.g. S100 for 100 rpm setting).

Basic manual mode

In the GUI “MANUAL” menu, the user can select the following manual mode: See (Figure 48 - Basic Manual Modes screen).

■ MPG mode.

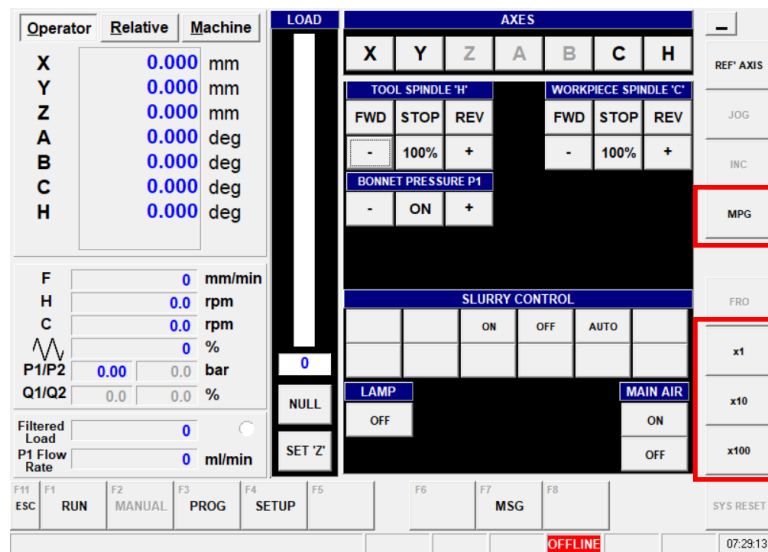

Figure 48 - Basic Manual Modes screen

MPG mode

Allows the Manual Pulse Generator (MPG) hand wheel to move the selected axis irrespective of the axis motion selected (e.g. X+ or X-). The hand wheel (MPG) will move the axis in either direction depending on the rotation direction of the hand wheel.

This is done by selecting the required option in the GUI, i.e. X1, X10 or X100 and then rotating the “MPG” hand wheel. The selected axis will move in the increments chosen.

The highlighted axis will move in increments as specified in the multiplier. 1X, 10X, 100X.



The increments in the multiplier are defined as follows:

- X1** = 1 µm increments
- X10** = 10 µm increments
- X100** = 100 µm increments

Tool spindle and work piece spindle commands

The tool spindle and work piece spindle may be manually operated by selecting options from the “TOOL SPINDLE (S)” and “WORKPIECE SPINDLE (C)” section of the GUI “MANUAL” page. See (Figure 49 - GUI Manual page).

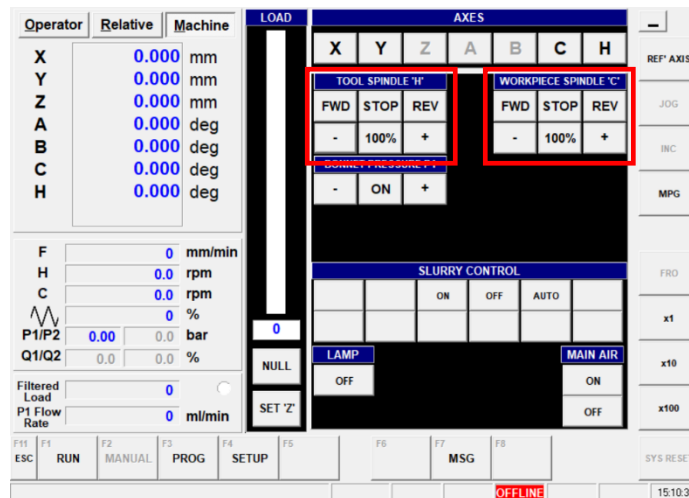

Figure 49 - GUI Manual page

Tool spindle (S) section

- “FWD”: Causes the H-axis to rotate in the M03 direction at the last speed defined either in a CNC program or the MDI “COMMAND LINE” see ([H axis Configuration](#)). If no speed has been defined the spindle will remain static.
- “STOP”: Causes the spindle to stop rotating.
- “REV”: Causes the spindle to rotate in the M04 direction at the last speed defined either in a CNC program or the MDI “COMMAND LINE” see ([MDI Mode](#)). If no speed has been defined the spindle will remain static.
- “DEC”: If the spindle is rotating then the speed is decreased by 5 % for each press.
- “100 %”: Resets the spindle speed to the last defined speed.
- “INC”: If the spindle is rotating then the speed is increased by 5 % for each press.

Work piece spindle (C) section

The options available are:

- “FWD”: Causes the C-axis to rotate in the M23 direction at the last speed defined either in a CNC program or manually by program MDI “COMMAND LINE” see [\(MDI Mode\)](#). If no speed has been defined the spindle will remain static.
- “STOP”: Causes the spindle to stop rotating.
- “REV”: Causes the C-axis to rotate in the M24 direction at the last speed defined either in a CNC program or manually by program MDI “COMMAND LINE” see [\(MDI Mode\)](#). If no speed has been defined the spindle remains static.
- “DEC”: If the spindle is rotating then the speed is decreased by 5 % for each press.
- “100 %”: Resets the spindle speed to the last defined speed.
- “INC”: If the spindle is rotating then the speed is increased by 5 % for each press.

Axis over-travel

Under normal conditions the axes are protected from over travel by software limits.

On reaching a software limit the axis decelerates to a stop and an alarm message displays on the CRT.

- To recover from a software limit alarm, manually jog the axis in the opposite direction. It will then be necessary to clear the alarm by pressing the “RESET” button.